

HRU ECO 4 Technical Guide

System 4

Continuous Mechanical Supply and Extract
Ventilation with Heat Recovery

Appendix Q Eligible



Climate for life.

Technical Guide for a Climate for Life



The Itho Group was founded in 1919. In the years since, the company has established itself as the market leader in indoor climate systems. Complementing its unrivalled ventilation systems, Itho also designs and manufactures high efficiency boilers, solar hot water systems, ground source heat pumps and other energy-saving systems at its headquarters in Schiedam, Netherlands. Itho Ventilation Limited, based in Burton on Trent, is the company's first subsidiary outside the Netherlands.



Reduced energy consumption, yet improved comfort. The healthiest possible interior atmosphere, yet lower running costs.

These are the seemingly contradictory goals that we've been achieving at Itho for more than 90 years, proving that we can enjoy a superior living environment within the home and protect our natural environment.

We call this a Climate for Life. This means that the homes you build can provide fresh filtered air whilst costing less to ventilate and emitting fewer emissions.



This Technical Guide gives all the required details to enable you to achieve this natural balance and the right Climate for Life.

Installation and user manual

Your HRU ECO 4 installation and user manuals will be supplied with the unit. Further copies are available from Itho Ventilation Limited or on line at www.itho.co.uk.

Location

The HRU ECO 4 can be installed

in all types of home, in closed rooms, lofts, storage rooms or airing cupboards.

Mounting

Fix the unit to a wall with a minimum mass of 200 kg/m² using the mounting bracket (supplied with the unit).

Ducting

Ducting within the dwelling should be either 204mmx60mm modular plastic or 125mm

diameter rigid, plastic ducting. All the ducting joints need to be made air tight, with the use of tape and/or non-setting mastic. This will ensure that the system works to it's designed efficiencies.

Commissioning

Once installed the system will need to be set up and commissioned to comply with the SAP Appendix Q, MVHR Installation Guide and Check List.

HRU ECO 4 variations available

UK CODE	PRODUCT	m ³ /hr	Voltage
105-0058	HRU ECO 4 (House) 5 core cable	325	230
105-0060	HRU ECO 4 (House) RF	325	230
105-0059	HRU ECO 4 (Apartment) 5 core cable	325	230
105-0061	HRU ECO 4 (Apartment) RF	325	230

Electrical connection

Connect the HRU ECO 4 to a 230V 50Hz power supply. A flying lead is attached to the unit using a 3amp fuse as standard. A double pole isolation switch with a minimum contact gap of 3mm must be fitted. The unit is double insulated so does not need to be earthed. As standard, the electrical connection on the unit is positioned on the left hand side. When the unit is reconfigured for mirrored/handed installation this connection will be positioned on the right hand side.

Motors

The HRU ECO 4 features two energy efficient DC motors. Backward curved blades on the impellers maximise air supply and extraction rates and help keep the unit clean.

Exhaust and supply connections

Diameters of all exhaust and supply connections are 150 mm (internal) and 180 mm (external) for the attachment of modular accessories. An embossed indicator on every connection

shows the direction and source of the air.

Counter flow heat exchanger

The HRU ECO 4's heat exchanger comprises triangular canals through which incoming and outgoing air flows. Each canal is surrounded by canals with air flowing in the opposite direction, creating a huge surface area for heat exchange.

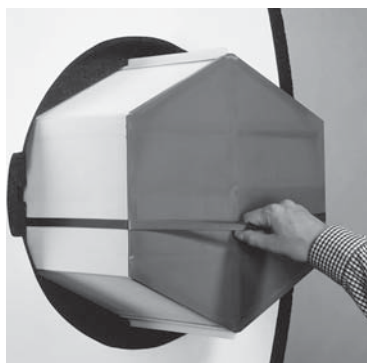

Removing the Heat Exchanger

100% summer bypass valve

The HRU ECO 4's automatic temperature controller will open the bypass valve when:

- the inside temperature is higher than required (not adjustable).
- the inside temperature is higher than the outside temperature.

- the outside temperature exceeds 19° C for an extended period – dependent upon exact temperature.

Frost protection device

The frost protection device, which protects the unit from freezing in low temperatures, works as follows:

with the valve open the HRU ECO 4 mixes internal air with fresh, incoming air at the same time the supply fan increases speed to maintain fresh air volumes as the temperature drops, fan speed decreases until a minimum is reached.

Meanwhile, the exhaust fan speed increases in extreme low temperatures the supply fan switches off and the frost protection device closes.

The exhaust fan, however, continues to operate

After approximately 90 minutes, the air supply fan restarts at low speed and the frost protection valve opens to reassess the risk of freezing. As the temperature rises, the reverse of the above process begins.

Sound proofing

Apply the sound insulating flexible pipe (type FGD 180-50, D=180mm L=500mm) provided between the air supply to the dwelling and the unit. A working space of 750mm should be allowed to accommodate joining pieces.

Condensation drainage

There is a condensation drain located at the bottom of the unit which needs to be discharged to a suitable location; i.e. soil vent pipe, grey water harvesting system. A "p" trap or equivalent approved trap, is required to stop any odours re-entering the HRU ECO 4.

Access

Allow a minimum of 500mm in front of the unit for easy servicing of filters and the heat exchanger.

Capacity setting

There are two potentiometers on the side of the HRU ECO 4 unit for controlling the low and high speed settings. The unit

automatically calculates the mid position between these settings. The factory setting for the high position is 225 m³/h at 100 pascals. The potentiometer should not be adjusted unless the required volumes are unattainable with room grilles.

IMPORTANT

Do not place any items on top of the automatic frost protection valve. Anything falling into the unit when the valve opens will prevent the mechanism from functioning.

Filters

The HRU ECO 4 comes with two G3 filters. The first of these, between the exhaust duct from the house and the heat exchanger, absorbs dust and grease and minimises dirt build-up. The second, between the fresh air inlet and the heat exchanger, cleans incoming air before it reaches the dwelling -

also preventing the heat exchanger from becoming dirty. Both filters can be removed, cleaned and replaced by the occupant without having to remove the front cover.

Maintenance

Maintain the HRU ECO 4 with these simple procedures:

- clean the filters when the dwelling is completed.
- inspect and clean or replace the filters annually.
- The heat exchanger to be cleaned every 6 years. This can be done by taking it out of the unit, rinsing in soapy water, drying and then replacing.
- depending on pollution levels, also clean the motor and fan blade.

New filters are available in sets and all spare parts can be changed without tools. We offer the first set of replacement filters FREE of charge,

UK CODE	PRODUCT
106-0902	HRU-4 G4 Standard (2 Filter Pack)
106-0903	HRU-4 F7 Pollen (2 Filter Pack)



once the unit has been registered on line at www.itho.co.uk.

Furthermore:

- the complete service module (motors, fans, power supply and controls) can be removed or replaced without disconnecting the ducts

Control

The HRU ECO 4 can be controlled in various ways. Either using a wired three-way control unit and/or wireless RFT three-way control unit with integral timer.

A range of external environmental sensors such as CO2 and humidity detectors, PIR sensors and timer switches can

be fitted to the HRU ECO 4 to enhance ventilation performance and ease of control.

Wired three-way switch

The wired control unit is connected to the unit – see wiring diagram.



It is possible to have multiple controllers, they would need to be wired in parallel. The unit will run at the highest setting of all the controllers.

Wiring Diagrams

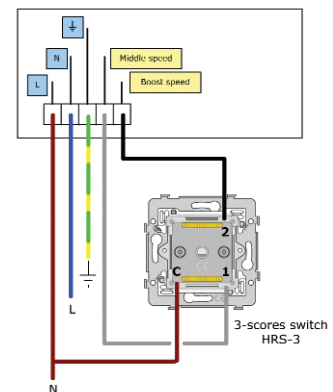

With an HRS-3 Speed Controller

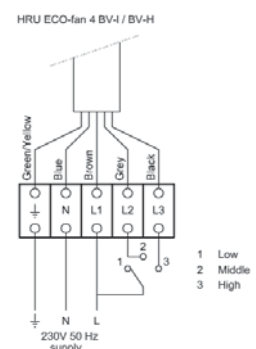

With a 3 way switch by others

RFT three-speed controller

The receiver for the control signal is factory-fitted into the fan. The switch enables users to select speed settings. It should be located in a wet room, preferably the kitchen or bathroom. Further switches for controlling the fan from other areas such as a utility room, en-suites etc. can easily be added either at initial installation or at a later stage. The last used switch is the master.



RFT 3 Speed Controller

To install, just press the control unit onto a tile or wall with the double sided adhesive tape supplied or fix with a screw. Each unit is supplied with an

installation and user manual. Do not place the RFT control switch onto a metal surface.

RFT transmission information

- transmission range is 100m in free air.
- transmission indoors is possible through a maximum of two concrete floors.
- pointing of transmitter towards the fan is not necessary.
- frequency 868 MHz, no licence or external antenna required.

Timer function

The RFT control switch also features a timer which can be used to select the high speed setting for 10, 20 or 30 minutes, after which the fan reverts to its low speed. Press the timer button once to activate high speed for 10 minutes, twice for 20 minutes and three times for 30 minutes. The timer function can be over-ridden at any time by pressing any of the three speed buttons.

Warranty

The unit is guaranteed for two years from the date of installation.

Ventilation performance for life

To get the very best in ventilation performance and energy efficiency from your HRU ECO 4, follow the instructions in the UK Installer Manual that you will receive with your unit. This will also help you comply with all UK and RoI Building Regulations and SAP Appendix Q requirements. Further copies of the UK Installer Manual are available from Itho Ventilation Limited or online at www.itho.co.uk.

Quality Assured

Before leaving our factory in Etten-Leur in the Netherlands, every Itho product is thoroughly tested, logged and tracked.

Code for Sustainable Homes

A New National Standard



The Code for Sustainable Homes has been developed to improve sustainable building practice for new homes. It has been prepared by the Government who worked with the Building Research Establishment (BRE) and Construction Industry Research and Information Association (CIRIA), and consulted a Senior Steering Group consisting of Government, Industry and NGO Representatives.

Intended as a single national standard for designers and constructors of dwellings, the Code for Sustainable Homes is a means of driving continuous

improvement, innovation and achievement in sustainable home building.

The Code complements the system of Energy Performance Certificates which was introduced in June 2007 under the Energy Performance of Buildings Directive (EPBD). From 1 May 2008 it became mandatory for all new homes to be rated against the Code and include a Code or nil-rated certificate within Home Information Packs.

The Code measures the sustainability potential of a new dwelling and provides a rating for the 'whole home' as a package. It

uses a 1 to 6 star rating system to indicate the energy saving credentials of a new home and sets minimum standards for energy and water use. In England, the Code replaces the EcoHomes scheme developed by the BRE.

The Code also gives buyers better information about the environmental impact of their new home and its potential running costs. It will inform future developments of the Building Regulations regarding carbon emissions and give developers increased regulatory certainty.



Code for Sustainable Homes – the route to 2016

By the year 2016, all new build homes across the UK must be zero carbon. To achieve this, the Code for Sustainable Homes, published by the Department for Communities and Local Government, sets out recommended incremental energy efficiency targets that will enable constructors to meet this target.

The table shows the staged percentage reductions in dwelling emission rates proposed by the Code. Building Regulations Part F (ventilation) and Part L (conservation of fuel

and power), effective October 2010, call for new homes to make emissions reductions of 25% over Target Emission Rate, thus making the Code Level 3 target mandatory. It is expected that future updates to the Building Regulations will incorporate the Code’s recommendations for Levels 5 and 6 as 2016 approaches.

At Itho, we’re already there. The HRU ECO 4 – our continuous mechanical supply and extract ventilation system with heat recovery (MVHR) - is more than ready for the airtight home of 2016.

Code Level	Minimum percentage reduction in Dwelling Emission Rate Over Target Emission Rate
Level 1 (★)	10
Level 2 (★★)	18
Level 3 (★★★)	25
Level 4 (★★★★)	44
Level 5 (★★★★★)	100
Level 6 (★★★★★★)	‘Zero Carbon’ Home

Building Regulations

The 2006 Edition of the UK Building Regulations Approved Document F1: Means of Ventilation (applicable in England and Wales) details four clearly defined systems of ventilation to dwellings.

The requirements across the rest of the UK vary slightly: in Northern Ireland, the requirement to meet Code Level 3 in public sector housing became effective in April 2008. The Scottish Government set out its targets in its Low Carbon Standards Strategy for Scotland document in December 2007. This calls for CO₂ reductions in homes of 60% over and above the 2007 Building Standards by 2013 – and it too is targeting zero emissions from 2016 onwards.

The Republic of Ireland has adopted the EU Directive on the Energy Performance of Buildings. This means that marketers of property for sale or rent have been obliged to prepare a Building Energy Rating

(BER) certificate since January 2009. This applies to new and existing buildings.

System 4 - Continuous Mechanical Supply & Extract with Heat Recovery (MVHR) provides continuous balanced mechanical central supply and extract from a unit positioned in a loft or cupboard space. An integral heat exchanger recovers a large percentage of heat energy from extracted air as it leaves the dwelling.

System 4 requires minimum high rates of extraction to be achieved in wet rooms (kitchen: 13 l/s; utilities and bathrooms: 8 l/s; sanitary only: 6 l/s).

Calculating ventilation rates

The zero carbon home allows for a maximum permissible air permeability of less than 3m³/hr/m² @50Pascals. It is probable that this will change to 5m³/hr/m² in the October 2010 edition of Part F. To calculate ventilation rates appropriate to this level of airtightness, follow these three steps.

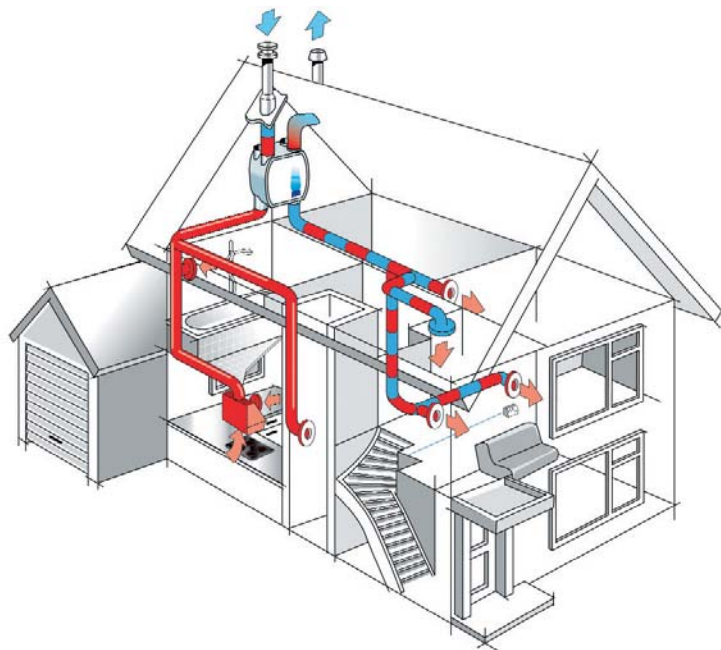

1. Determine the whole building ventilation rate from Table 1.1b. Allow for infiltration by subtracting for multi-storey dwellings: $0.04 \times$ gross internal volume of dwelling heated space (m^3) for single storey dwellings: $0.06 \times$ gross internal volume of dwelling heated space (m^3).

2. Calculate the whole dwelling extract rate at maximum operation by adding the individual room rates for minimum high rate from Table 1.1a.

3. The required air flow rates are as follows: Maximum Extract Rate (boost) is the greater step of 1 and 2 above. The minimum individual room extract rates

should be at least those given in Table 1.1a for minimum high rate. Minimum air supply rate should be at least the whole building ventilation rate in 1 above.

The minimum low rate is calculated by taking the number of bedrooms in the dwelling and applying the l/s value from Table 1.1b. In addition, the rate should be no less than 0.3 l/s per m^2 of internal floor area (all storeys). For each additional occupant over and above the anticipated two for the first bedroom and one for each additional bedroom, a further 4 l/s must be added to the extract rate. The air infiltration allowance must be calculated and included. This would be zero

if the air tightness is $\leq 3m^3/h/m^2$ (Please check latest Building Regulations) or as determined in step 1.

MVHR systems provide uninterrupted ventilation, extracting warm, stale air from wet rooms. Warmth from this extracted air is transferred into the fresh air drawn into the home as it passes through an integral high efficiency synthetic heat exchanger on its way to the habitable rooms.

Table 1.1 a

Room	Minimum Intermittent Extract Rate	Continuous Rate	
		Minimum high rate	Minimum low rate
Kitchen	30 l/s (adjacent to hob); or 60 l/s elsewhere	13 l/s	Total extract rate must be at least the whole building ventilation rate in table 1.1b
Utility Room	30 l/s	8 l/s	
Bathroom	15 l/s	8 l/s	
Sanitary Accommodation	6 l/s		

Table 1.1 b

Whole Building Ventilation Rate (l/s)	Number of bedrooms in dwelling				
	1	2	3	4	5
	13	17	21	25	29
Minimum value in any dwelling of 0.3 l/s per m^2 floor area.					

SAP Appendix Q

The Standard Assessment Procedure (SAP) Appendix Q website, www.sap-appendixq.org.uk, is a UK-based government led initiative for demonstrating compliance with Building Regulations within Part L (England and Wales), Section 6 (Scotland) and Part F (Northern Ireland). Also Dwelling Energy Assessment Procedure (DEAP) for the Irish Republic.

SAP Appendix Q is a database of energy efficient technologies which have been assessed for performance. The results can be input into a SAP assessment submission.

BRE test results for the HRU ECO 4

The Energy Saving Trust's 'Demonstrating Compliance - Best Practice', states that MVHR units must have a specific fan power (SFP) of 1.0 W/l/s or less and a heat recovery efficiency of 85% or above. The HRU ECO 4 exceeds both of these figures (←0.46W/l/s and up to 91% respectively)

Test report – SAP Appendix Q – MVHR Test report Number 244-174
Test report issued 02/04/08

Standard Assessment Procedure 2005 – Appendix Q MVHR Product Data

Product tested **HRU ECO 4**

Results for Appendix Q at minimum flow rate condition

This product has only been tested with rigid ductwork and it is not applicable for SAP Appendix Q if installed with flexible ductwork.

Table Q2 – Systems with rigid ductwork only

Exhaust terminal configuration	Fan speed setting	Total flow supply rate (l/s)	Total exhaust flow rate (l/s)	Specific fan power (W/l/s)	Heat recovery efficiency (%)	Energy Saving Trust Best Practice Performance Compliant
Kitchen + 1 additional wet room	Supply & Extract – 100% variable	15.0	15.0	0.46	91	Yes
Kitchen + 2 additional wet rooms	Supply & Extract – 100% variable	21.0	21.0	0.46	90	Yes
Kitchen + 3 additional wet rooms	Supply & Extract – 100% variable	27.0	27.0	0.50	88	Yes
Kitchen + 4 additional wet rooms	Supply & Extract – 100% variable	33.0	33.0	0.56	88	Yes
Kitchen + 5 additional wet rooms	Supply & Extract – 100% variable	39.0	39.0	0.65	87	Yes
Kitchen + 6 additional wet rooms	Supply & Extract – 100% variable	45.0	45.0	0.75	87	Yes
Kitchen + 7 additional wet rooms	Supply & Extract – 100% variable	51.0	51.0	0.87	87	Yes

These figures must NOT be entered directly into the SAP worksheet or any software. They must be entered into the SAP Q Calculation Spreadsheet



Technical Specifications

	Capacity [m³/h]	Pressure [Pa]	Power [W]*	Current [A]*	Voltage [V]*	Cos phi *	Thermal efficiency [%]
Mode 1 Minimum mode	50	10	8	0.05	230	0.07	98
Mode 1 Low mode	75	20	12	0.1	230	0.55	98
Mode 2 Medium mode	150	40	29	0.24	230	0.53	96.2
Mode 2 Medium mode	150	80	38	0.31	230	0.53	96.2
Mode 3 High mode	225	100	74	0.59	230	0.59	94
Mode 3 High mode	225	150	88	0.69	230	0.56	94
Mode 3 High mode	275	100	106	0.83	230	0.56	93
Mode 3 High mode	275	150	126	0.99	230	0.56	93
Mode 3 Maximum mode	325	100	156	1.22	230	0.56	92
Mode 3 Maximum mode	325	150	176	1.36	230	0.56	92

* Values to be used in the EPC calculation at 230V, according to NEN5128.

Other technical specifications

Power supply: 230V

Condensate discharge diameter: 40mm external

Frequency 50Hz

Filterclass: G3

Dimensions: height 848mm

width 730mm

depth 479mm

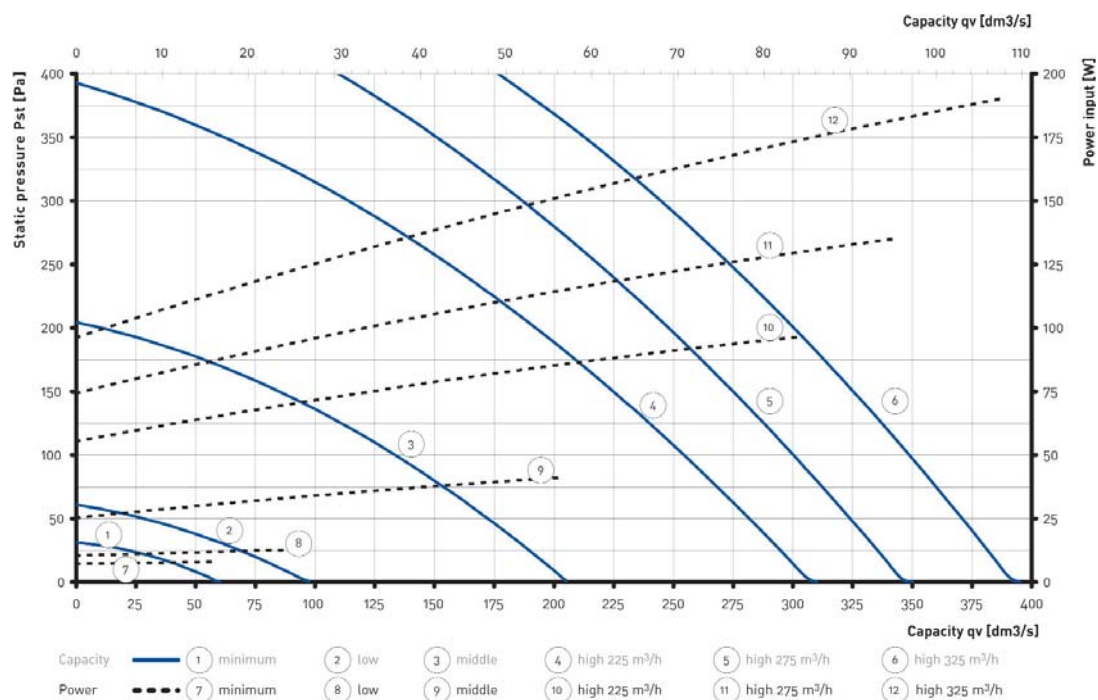

Sound Power Spectrum

	total [dB(A)]	63 Hz [dB]	125 Hz [dB]	250 Hz [dB]	500 Hz [dB]	1000 Hz [dB]	2000 Hz [dB]	4000 Hz [dB]	8000 Hz [dB]	
Breakout	25 m³/h 20 Pa	←23.5	47.2	30.4	23.3	21.4	13.2	11.5	4.7	9.4
	75 m³/h 20 Pa	30.5	45.2	34.2	32.1	29.6	24.2	18.1	5.6	9.3
	150 m³/h 80 Pa	46.5	46.6	44.9	46.3	44.8	40.9	39.4	25.1	15.4
	225 m³/h 100 Pa	53.8	50.0	48.1	52.7	52.2	47.8	47.3	35.7	24.1
	225 m³/h 150 Pa	55.0	53.6	48.7	53.0	53.8	48.9	48.7	38.6	29.5
	275 m³/h 100 Pa	57.5	58.2	49.6	56.4	55.7	51.5	50.8	41.3	29.4
	275 m³/h 150 Pa	58.5	61.8	50.4	56.8	56.7	52.5	51.8	43.4	38.4
	325 m³/h 100 Pa	60.5	58.6	50.4	58.9	58.1	54.7	53.7	45.6	33.7
	325 m³/h 150 Pa	61.5	54.7	51.8	59.2	59.3	55.6	54.5	47.2	37.0
Exhaust	25 m³/h 20 Pa	20.5	46.2	19.7	22.6	15.2	10.3	7.1	4.3	9.0
	75 m³/h 20 Pa	28.5	46.7	28.8	33.0	25.4	22.3	12.1	4.7	8.8
	150 m³/h 80 Pa	42.5	45.9	37.3	46.9	40.0	37.0	30.6	15.1	12.5
	225 m³/h 100 Pa	49.5	47.0	41.8	53.7	47.6	43.2	37.7	25.3	14.3
	225 m³/h 150 Pa	50.5	46.8	43.2	53.6	49.4	44.1	38.9	27.0	14.9
	275 m³/h 100 Pa	53.5	46.8	43.6	58.4	50.8	46.9	40.9	30.7	16.8
	275 m³/hh 150 Pa	54.0	46.8	46.1	58.1	52.1	47.8	42.0	32.5	17.4
	325 m³/h 100 Pa	56.5	47.2	44.7	61.4	53.6	49.9	43.8	35.1	19.8
	325 m³/h 150 Pa	57.0	48.6	46.5	60.6	54.9	50.6	44.5	36.3	20.6
Inlet*	25 m³/h 20 Pa	30.0	33.6	29.4	29.5	29.7	22.7	21.7	7.2	12.0
	75 m³/h 20 Pa	40.5	47.3	40.8	40.8	40.2	35.3	28.1	13.4	12.7
	150 m³/h 80 Pa	56.5	50.0	51.9	56.7	54.9	51.3	48.9	36.2	22.9
	225 m³/h 100 Pa	65.3	50.7	56.0	64.4	65.6	58.6	57.5	47.0	33.6
	225 m³/h 150 Pa	66.0	51.4	56.7	64.7	65.5	59.7	59.1	48.9	35.5
	275 m³/h 100 Pa	69.5	52.1	57.2	68.0	69.6	62.4	61.1	52.7	39.1
	275 m³/h 150 Pa	70.5	53.0	58.0	58.8	70.6	63.3	62.2	54.6	40.5
	325 m³/h 100 Pa	73.0	53.2	57.7	70.3	72.9	65.9	64.2	57.2	43.6
	325 m³/h 150 Pa	74.0	54.1	58.7	71.3	74.1	67.0	65.0	58.7	45.0

* Please Note: This test did not include the silencer (supplied with the unit). The silencer can reduce the noise levels by a further 7 to 10 dB(A).

Suspension

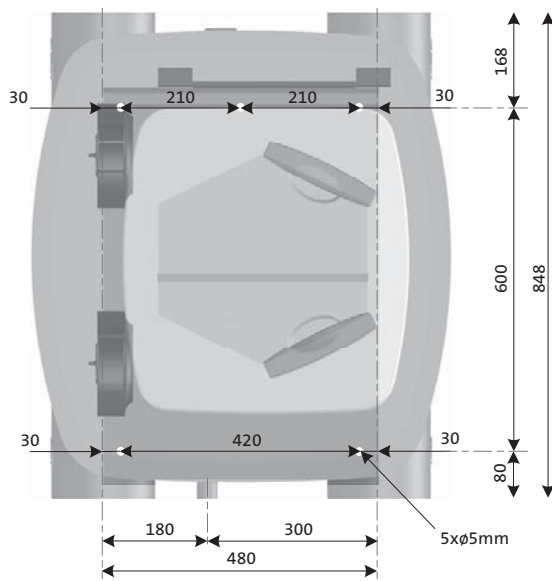

Mirrored suspension

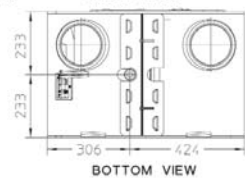
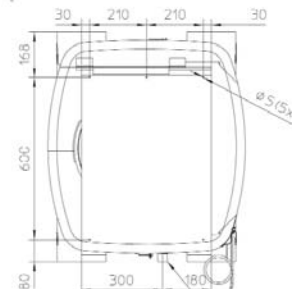
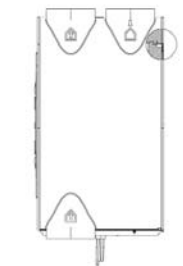
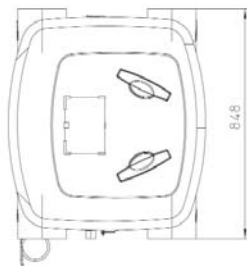
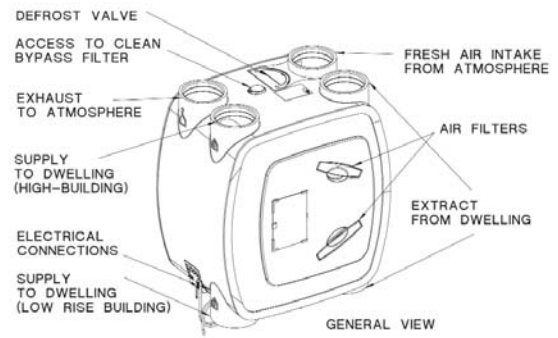
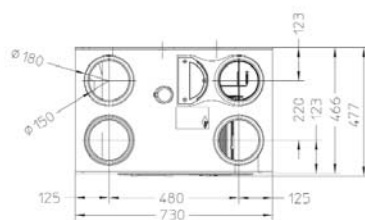
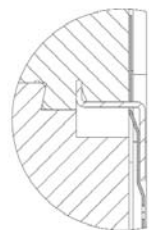
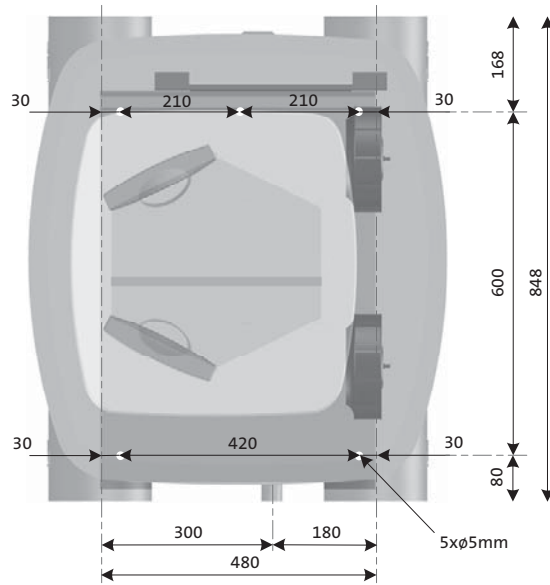

Climate for life

Vision.

The ultimate challenge in climate management is the realisation of a comfortable, healthy indoor climate that doesn't use energy. This will have to be solved by reducing energy demands and having very efficient equipment and sustainably created energy. In the long run, only electricity can be generated in a sustainable way, which is why, in our point of view, we are moving towards an 'all electric society'. We are fascinated by this new vision of society and with solving the apparent contradiction between comfort and energy consumption.

Mission statement.

To make the residential environment climate neutral.

The development.

Itho saw in time that climate change also requires companies to change. That is why Itho has transformed itself over a ten-year period from being a Dutch trading company into a self-developing manufacturer that distributes its innovative products throughout Europe, partly through its own outlets.

The future.

The challenge to stop climate change is becoming greater and greater. Because of this the number of innovations will increase and we will introduce these innovations in a growing number of European countries. A lot will be expected of us and we expect to find an increasing number of partners and colleagues that share our vision, motives and vigour.

NuTech Renewables Ltd
Unit 11, Warrenpoint Enterprise Centre
Newry Road, Warrenpoint
Co. Down, BT34 3LA

Tel: + 44 (0) 28 417 53031

Email: info@nutechrenewables.com

www.nutechrenewables.com

Itho Ventilation Limited

10 Faraday Court
First Avenue
Centrum 100
Burton on Trent DE14 2WX
T 0845 250 8090
F 0845 250 8091
E info@itho.co.uk
I www.itho.co.uk



Climate for life.